

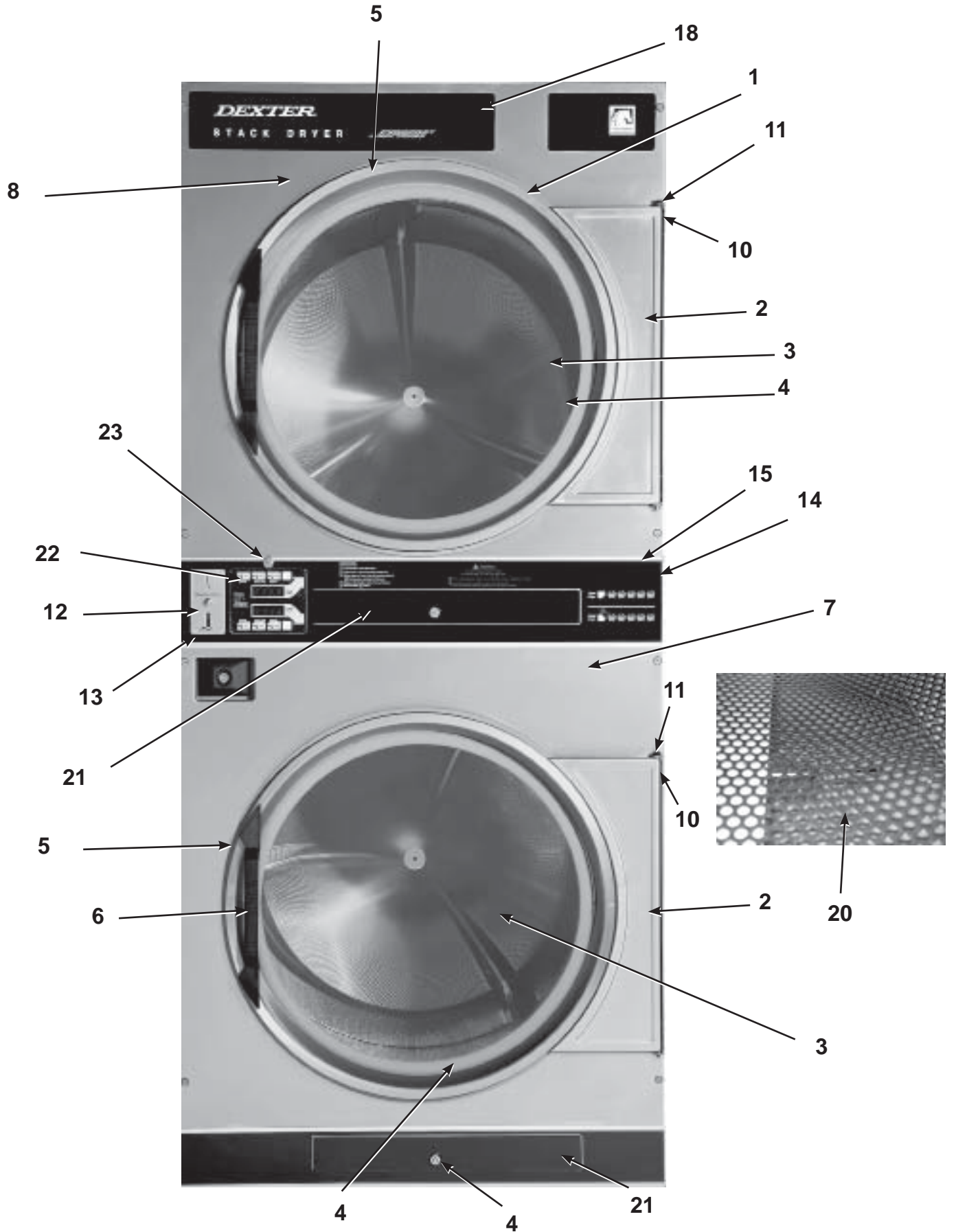

# Section 6:

Parts Data 60Hz  
DDBD50KC\_-



# Cabinet Group

Key	Part Number	Description	Quantity
*	9960-285-003	Door Assy., Loading Complete-Alm .....	2
*	9960-285-002	Door Assy., Loading Complete-Wht .....	2
*	9960-285-001	Door Assy., Loading Complete-SS .....	2
*	9960-285-007	Door Assy., Loading Complete-Chrome/BLK/SS .....	2
1	9960-284-002	Door Assy., Loading-SS(ring only) .....	2
1	9960-284-004	Door Assy., Loading-Chrome(ring only) .....	2
2	9982-353-003	Plate Assy., Hinge (Alm) No Pin .....	.2
2	9982-353-002	Plate Assy., Hinge (Wht) No Pin .....	.2
2	9982-353-001	Plate Assy., Hinge (SS) No Pin .....	2
*	9545-012-015	Screw, Hinge to Door .....	8
*	8640-413-002	Nut, Hinge to Door .....	8
3	9212-002-004	Glass, Door .....	2
4	9206-164-010	Gasket, Glass Gray .....	2
4	9206-413-002	Gasket, Glass Black .....	2
*	9548-117-000	Support, Door Glass .....	.2
5	9206-420-004	Gasket, Outer Rim Gray .....	2
5	9206-420-005	Gasket, Outer Rim Black .....	2
6	9244-082-001	Handle, Loading Door .....	2
*	9545-018-017	Screw, Handle 1/4-20 x 3/8 .....	4
*	9531-033-001	Stud, Door Catch .....	2
*	8640-413-001	Nut, Hex .....	2
*	8640-413-003	Nut, Acorn .....	2
*	9086-015-002	Catch, Loading Door .....	.2
*	8638-190-009	Pop Rivet for mtg. catch .....	4
*	8641-582-006	Lockwasher .....	4
*	8640-399-001	Spring Nut .....	.6
7	9989-521-004	Panel Assy., Front- Lower (Alm) .....	1
7	9989-521-003	Panel Assy., Front- Lower (Wht) .....	1
7	9989-521-001	Panel Assy., Front- Lower (SS) .....	.1
7	9989-517-009	Panel Assy., Front Lower EC (SS) .....	1
7	9989-517-011	Panel Assy., Front Lower EC (Wht) .....	1
7	9989-517-012	Panel Assy., Front Lower EC (Alm) .....	1
8	9989-517-004	Panel Assy., Front- Upper (Alm) .....	1
8	9989-517-003	Panel Assy., Front- Upper (Wht) .....	1
8	9989-517-001	Panel Assy., Front- Upper (SS) .....	.1
*	9277-054-001	Insulation Front Panel, half moon (top) .....	2
*	9277-054-002	Insulation Front Panel, half moon (bottom) .....	2
*	9545-008-014	Screw, FLHDCR, 10B x 1 .....	14
*	8641-585-001	Lockwasher .....	.6
*	8640-399-001	Nut, Spring .....	12
10	9544-069-003	Strap, Hinge (Alm) .....	.2
10	9544-069-002	Strap, Hinge (Wht) .....	.2
10	9544-069-004	Strap, Hinge (SS/Gray) .....	2
10	9544-069-005	Strap, Hinge (SS/Black) .....	2
*	9545-012-028	Screw, Hinge to Panel .....	8
11	9545-052-001	Screw, Door to Hinge Strap (Special Black Type) .....	.2
*	8641-436-003	Washer, Fiber .....	2
12	9021-001-010	Acceptor, Coin .....	1
*	9486-136-001	Retainer, Coin Acceptor .....	1
13	9545-053-002	Screw .....	4
*	9732-126-001	Switch ( for coin acceptor with extra actuator ) .....	.1

## Cabinet Group Continued

Key	Part Number	Description	Quantity
14	9994-032-001	Escutcheon, Upper .....	1
15	9435-022-001	Trim, Overlay-Upper Blue.....	1
15	9435-030-001	Trim, Overlay-Upper Black .....	1
16	9994-033-001	Escutcheon, Lower .....	1
17	9435-023-001	Trim, Overlay-Lower Blue.....	1
17	9435-031-001	Trim, Overlay-Lower Black .....	1
*	9545-020-009	Screw .....	20
18	9412-154-001	Nameplate Stack Dryer Express Blue.....	1
18	9412-167-001	Nameplate Stack Dryer Express Black .....	1
21	9866-005-001	Lint Drawer Assembly Blue .....	2
21	9866-005-004	Lint Drawer Assembly Black.....	2
21	9435-024-001	Overlay Trim, Lint Drwr-Blue .....	1
21	9435-032-001	Overlay Trim, Lint Drwr-Black.....	1
*	9532-074-003	Felt Seal ( back of lint screen assembly ) .....	2
*	9805-033-002	Lint Screen Assembly ONLY (no front) .....	2
*	9555-057-008	Replaceable Lint Screen Only.....	2
*	9555-057-010	Replaceable Lint Screen Only (Fine Mesh) .....	2
24	8650-012-004	Lock and Key, Lint Drawer .....	2
*	6292-006-010	Key 6101 only .....	2
*	9095-043-001	Cam, Lock .....	2
*	9545-008-001	Lint Screen Strap Hold Down Screws 10Bx 1/4 .....	32
22	9857-147-001	Controls Assy, Electronic Mounted With Membrane, Blue ...	1
22	9857-147-010	Controls Assy, Electronic Mounted With Membrane, Blue ...	1
22	9857-147-008	Controls Assy, Electronic Mounted With Membrane, Black ..	1
22	9857-147-011	Controls Assy, Electronic Mounted With Membrane, Black ..	1
22	9801-059-006	Membrane Switch Assy Blue .....	1
22	9801-100-001	Membrane Switch Assy Black.....	1
*	9627-869-001	Harness, Electronic Control .....	1
*	9627-854-001	Harness Coin Sw .....	1
23	8650-012-003	Lock and Key, Control .....	1
*	9095-041-001	Cam, Lock .....	1
*	6292-006-007	Key only 6324.....	1
*	9627-855-003	Harness, Heat Sensor .....	1
*	9277-041-017	Insulation Cabinet Cover .....	1
20	9501-004-003	Sensor Temp Control .....	2
*	9501-008-001	Bracket for Heat Sensor Mounting (Under Basket) w/ sensor..	2
*	9501-008-001	Bracket Temp Sensor w/ Sensor.....	1
*	9545-045-005	Screw, Round Head (Mounts sensor; phillips head).....	2
*	9209-037-002	Gromm.et, 3/16 ID .....	2
*	8544-006-001	Leg, Leveling 1/2" .....	4
*	9074-320-001	Cover, Cabinet (Top) .....	1
*	9732-253-001	DDAD Kit for Dryers without Neutral and using 208-240 volt ..	1
*	9732-102-013	LP Kit for DDAD Dryers.....	1
*	9732-243-001	Stack Dryer Trunion Puller.....	1
*	9555-057-010	Replaceable Lint Screen Fine Mesh Only .....	1
*	8640-276-002	Wire Nut Connector Grey.....	4
*	9527-007-002	Standoff Wire Saddle .....	8
*	9544-041-002	Strap - Bead Tie .....	1

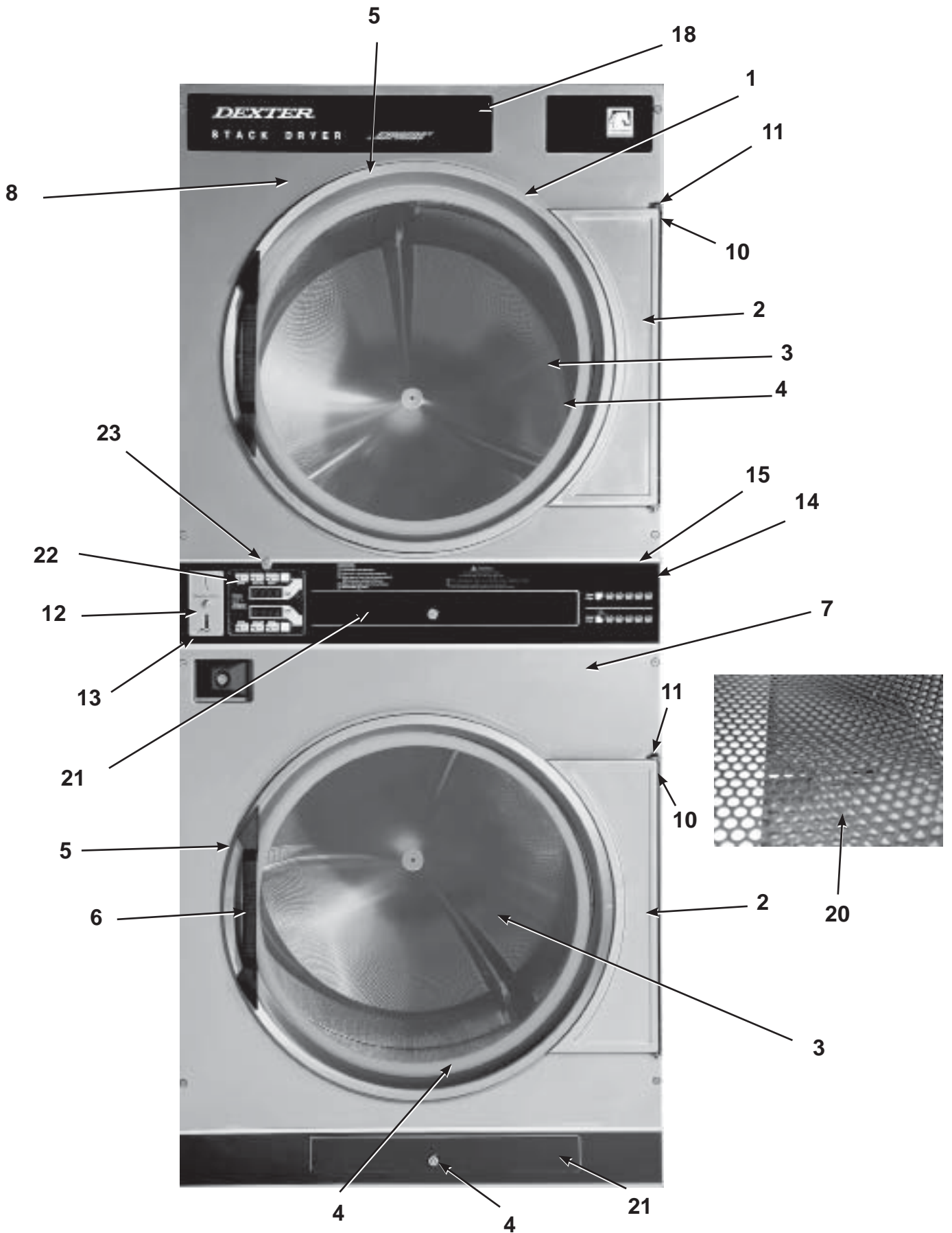

# Door Switch Group

Part Number	Description	Quantity
9539-487-001	Door Switches .....	2



## Hinge Plate Cover (after Serial # 220625 )

1	9074-340-002	Cover-Hinge, Black .....	2
Note: Before Serial # 220625 Holes can be drilled in hinge plate to install (#18 Drill bit).			
2	8636-018-001	Screw-TRHDCR, 10B x 3/8, Black.....	4

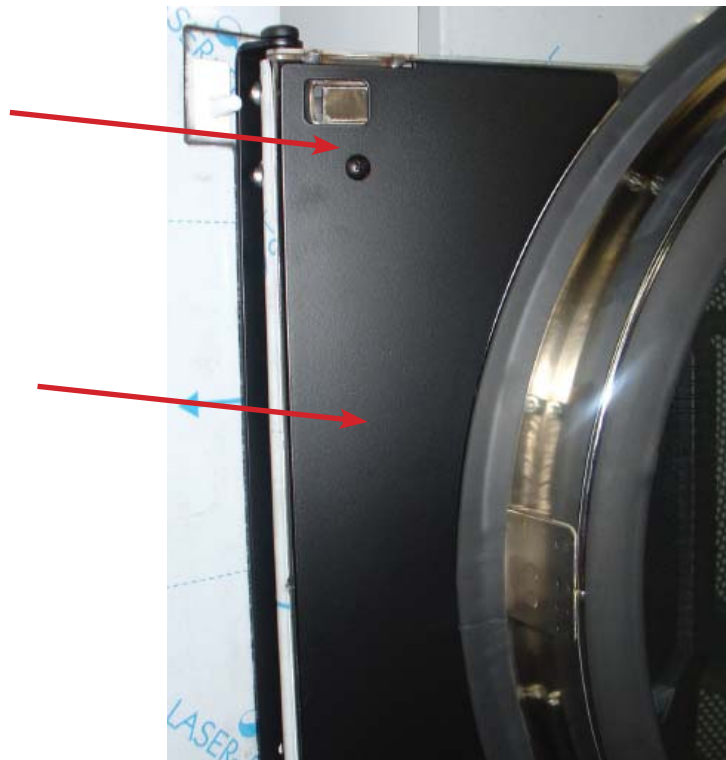

# Bearing Housing Group

Key	Part Number	Description	Quantity
J1	9241-189-002	Housing, Bearing .....	2
J2	9036-159-003	Bearing, Ball Rear.....	2
*	9538-183-001	Spacer, Bearing .....	2
*	9036-159-001	Bearing, Ball Front.....	2
J5	9545-017-017	Bolt, 1/2 x 3/4.....	8
J7	8640-417-002	Nut, 1/2 .....	8
*	9803-201-001	Bearing Housing Complete Ass'y (includes bearings,spacer) .....	2
J4	9545-017-018	Screw 1/2 x 1 1/2 .....	4

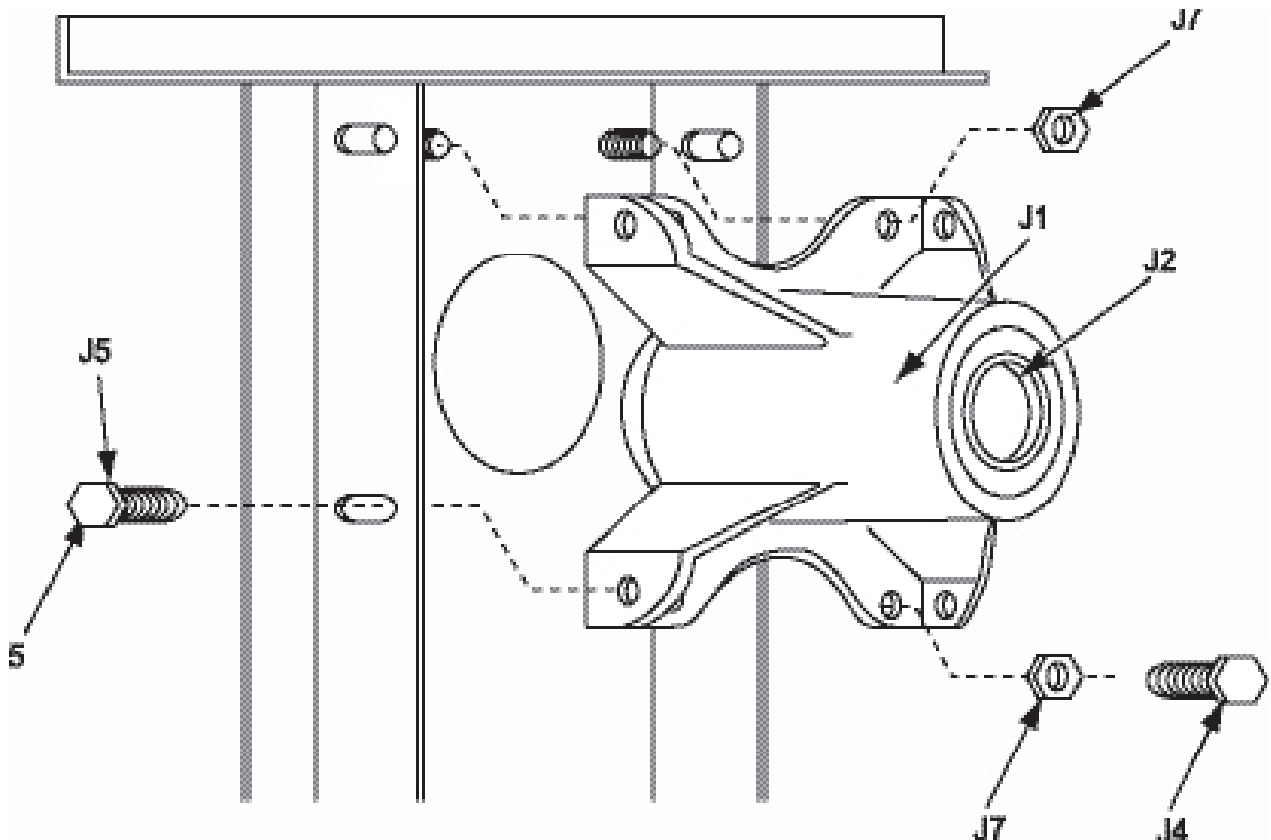
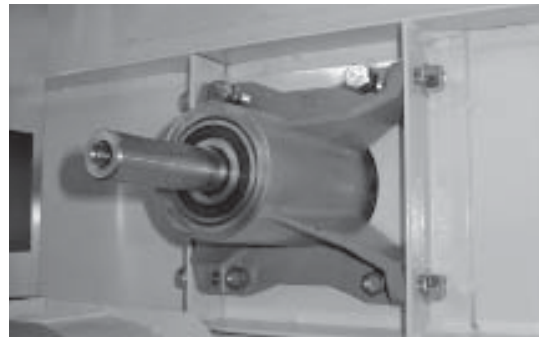

# Burner Housing Group

Key	Part Number	Description	Quantity
*	9803-207-001	Housing Assembly, Burner .....	2
1a	9452-730-001	Service Burner Plate Front... ..	2
1	9452-729-001	Service Plate baffle Recirculation Chamber Clean Out .....	2
*	9545-008-006	Screws .....	8
2	9545-008-001	Screw .....	16
18	9003-220-001	Angle, Burner Support .....	2
*	9545-008-006	Screw .....	4
17	9048-020-002	Burner, Main .....	4
*	9545-008-006	Screw 10AB x 3/8" .....	4
*	9454-824-001	Panel, Back Burner Housing.....	2
4	9545-008-001	Screw 10B x1/4" .....	8
5	9875-002-003	Electrode Assy, Ignition .....	2
19	9545-045-001	Screw, Electrode Mtg 8B x 1/4" .....	4
7	9379-186-001	Valve, Gas Shut Off .....	1
8	9857-134-001	Control Assy, Gas .....	2
9	9381-012-001	Manifold, Assy .....	2
*	9425-069-021	Orifice, Burner-Natural #27 .....	4
*	9425-069-022	Orifice, Burner-LP #44.....	4
10	9029-175-001	Bracket, Manifold .....	2
22	8615-104-038	Pipe Plug in end of Burner Manifold .....	2
*	9545-008-006	Screw .....	4
12	9576-203-002	Thermostat, Hi-Limit .....	2
*	9538-142-001	Spacer, Hi-Limit .....	4
*	9545-045-007	Screw 8B x 3/4" .....	4
13	9074-329-001	Cover, Hi-Limit Stat Ignitor .....	2
*	9545-008-006	Screw .....	6
*	9576-207-008	Thermostat, Safety Shutoff .....	2
*	9545-008-006	Screw .....	4
15	9825-062-001	Cover, Safety Stat .....	2
*	9545-008-024	Screw .....	6
16	9857-116-003	Control, Ignition Fenwall (3 trybox) .....	2
*	9732-102-013	Kit, LP Conversion DDBD Kit .....	2
*	9838-018-003	Welded One Piece Gas Pipe Assembly.....	1



# Burner Housing Group Photos

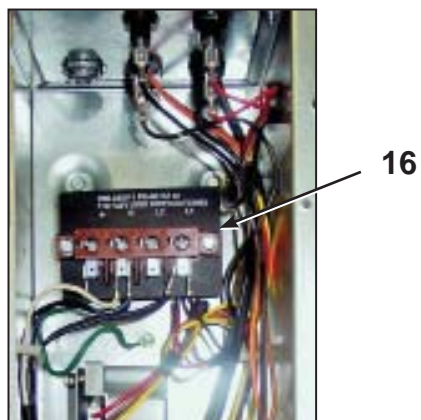
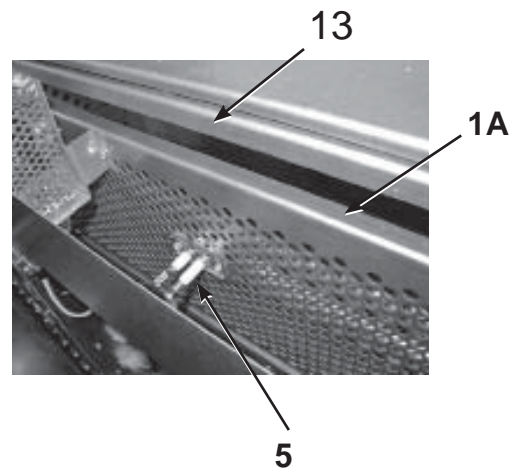
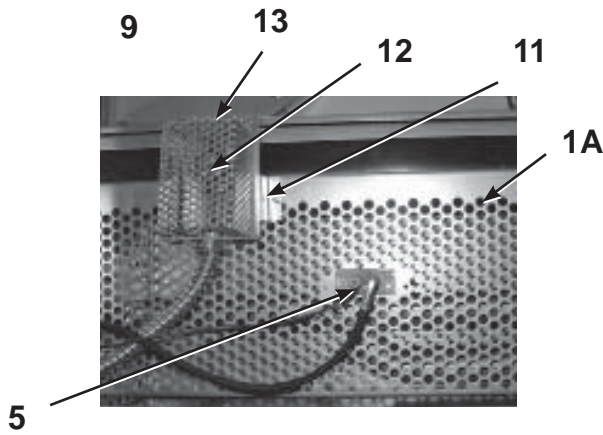
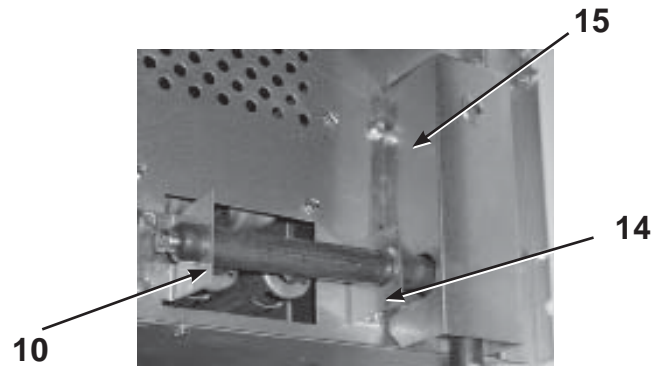
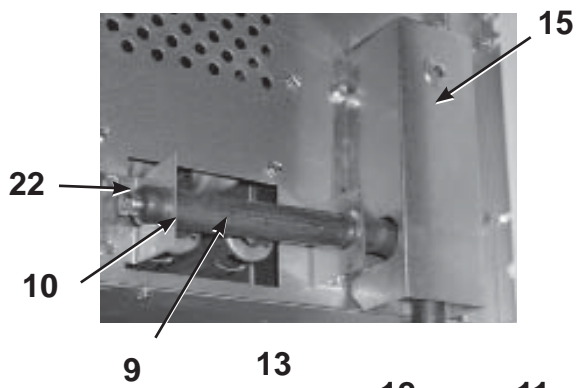
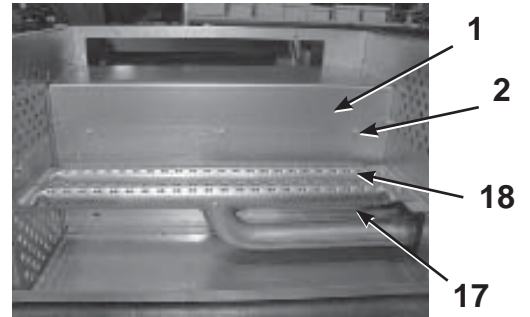
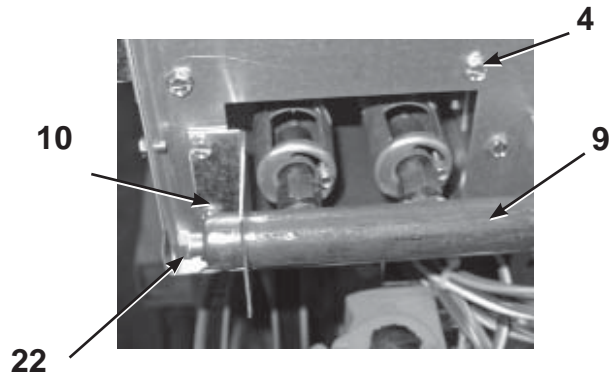

# Rear View

Key	Part Number	Description	Quantity
*	9627-861-001	Wire Harness Overtemperature Switch/Air Switch.....	2
*	9801-098-001	Switch Assy, Air Flow .....	2
1	9539-461-009	Switch, Air Flow .....	2
2	9029-200-001	Bracket, Switch- Air Flow .....	2
3	9008-007-001	Actuator, Switch.....	2
4	9451-169-002	Pin, Cotter .....	2
5	9545-020-001	Screw 4-40 x 5/8" .....	4
*	8640-401-001	Nut, Special Twin #4-40 .....	2
*	9550-169-003	Shield, Switch .....	2
7	9376-322-001	Motor, Drive .....	2
*	9452-770-001	Plate, Motor Mounting .....	1
8	9962-018-002	Plate, Impeller Mtg .....	2
*	9545-029-008	Bolt 3/8" - 16 x 3/4".....	8
*	8641-582-003	Lockwash Spring 3/8 .....	8
9	9545-018-019	Screw, Motor Plate to Back Assy. 1/4-20x 2 1/2.....	8
9	86411-582-007	Lockwasher 1/4.....	8
9	9538-163-006	Spacr.....	8
9	8641-581-017	Flat Washer 1/4 x 7/8.....	24
9	9209-086-002	Rubber Grommet.....	8
*	9538-166-006	Grommet Spacers.....	8
*	9545-028-013	Screw, Set.....	4
10	9962-017-002	Back Assy, Blower Hsg.....	2
11	9991-053-001	Support Assy, Intermed. Pulley .....	2
12	9545-029-010	Bolt, Rd Hd 3/8-16 x 1 1/4 .....	6
12	8640-415-004	Nut Flange Wizlock 3/8" - 16.....	6
12	8641-581-035	Washer, Flat .....	6
13	9545-029-003	Bolt, 3/8-16 x 1 1/2 .....	2
14	9861-022-001	Arm Assy-Tension, Complete .....	2
*	9487-200-003	Ring-Retaining .....	6
16	9908-048-003	Pulley Assy, Intermediate with bronze flange bearing .....	2
*	9036-145-002	Bronze Flange Bearing .....	4
17	9908-047-002	Pulley Driven Tumbler .....	2
19	9040-076-009	Belt, Drive Motor.....	2
20	9040-073-011	Belt, Driven Intermediate to Tumbler .....	2
21	9534-151-000	Spring, Tension .....	2
22	9099-012-005	Chain, Tension .....	2
23	9248-022-002	Hook, Tension .....	2
*	9451-146-001	Pin, Damper Hinge .....	2
*	9074-334-001	Cover Duct Upper .....	1
25	9973-032-001	Heat Recirculation Assembly Duct .....	2
27	9453-169-013	Motor Pulley - Driver .....	1
28	9545-028-013	Set Screws .....	2
30	9278-038-004	Impeller (Before Serial #231600.....	2
30	9278-043-001	Impeller (After Serial #231600 .....	2
34	8641-581-026	Washer, Flat 1/2" for Tumbler Pulley.....	2
35	9545-017-009	Bolt, 1/2"-13 x 1 1/4 .....	2
36	8641-582-016	Washer, Star 1/2" for Tumbler Pulley .....	2
*	9545-008-001	Screw 10 Bx 1/4" .....	6
*	9545-014-004	Bolt, 5/16-18 x 5/8" .....	8
*	8640-400-003	Nut, 5/16-18 .....	8
*	9538-184-001	Spacer, Shaft .....	2
*	9487-234-005	Ring Tolerance.....	2
*	9125-007-001	Damper Inside Duct Exhaust .....	2
*	9125-007-002	Damper Inside Duct Exhaust .....	1
*	8520-141-000	Nut, Spring .....	4
*	9074-335-001	Cover Duct Lower .....	1
*	9545-008-024	Screw 10ABx 3/8" .....	72

# Rear View Photos

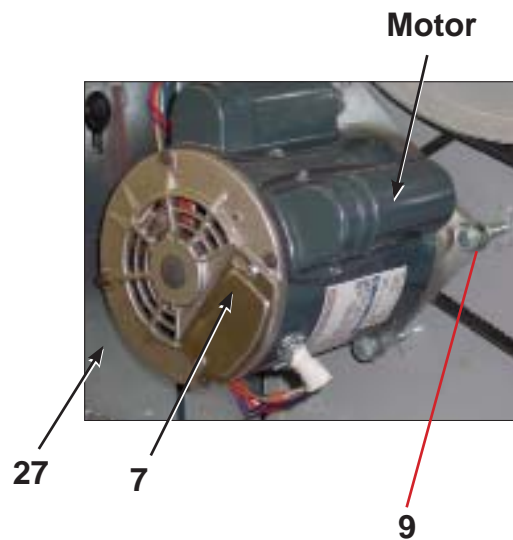
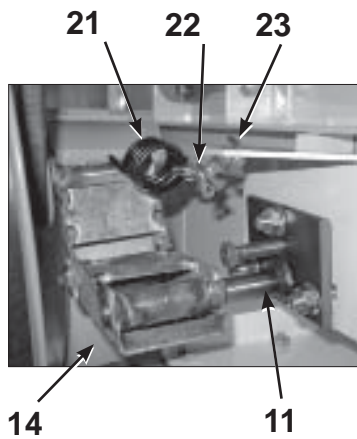
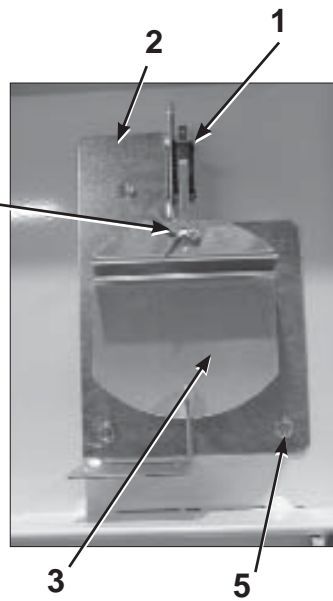
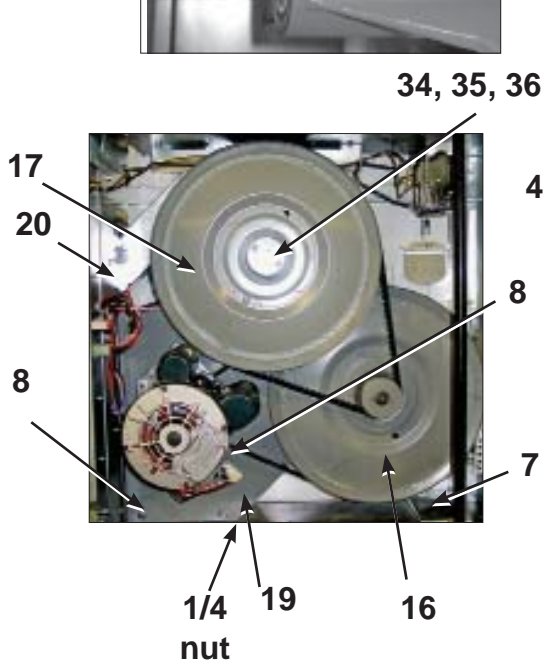
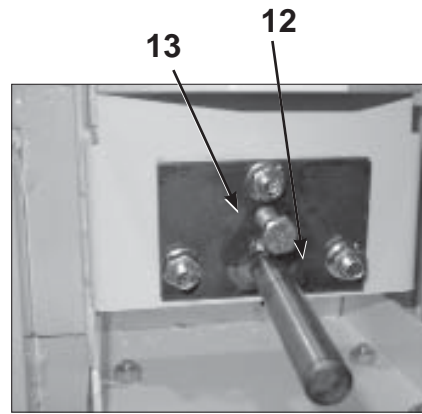
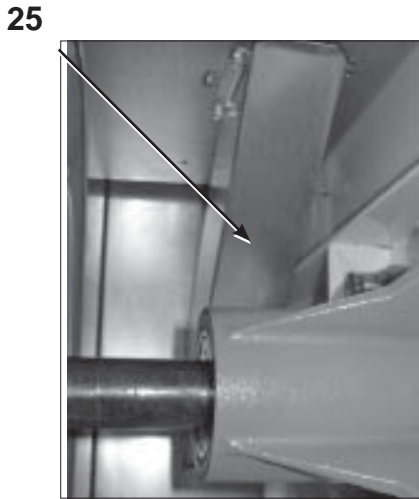

# Rear Panel & Cover Group

Key	Part Number	Description	Quantity
1	9208-090-001	Rear Guard Side Panel 1 .....	2
4	9545-008-024	Screws 10 AB x 3/8 .....	30
5	8502-649-001	Label - Connection Electrical .....	1
8	9208-089-001	Rear Guard Back Panel .....	2
10	8502-600-001	Label Warning & Notice .....	1
11	8502-645-001	Label - Instructions .....	1
12	9109-113-001	Transition Assembly Outlet .....	1
13	9074-320-001	Top Cover Dryer Panel .....	1
14	9550-188-001	Top Burner Housing Heat Shield Inlet .....	1
15	9074-321-001	Top Panel Burner Housing Cover .....	1



1



8

Screws

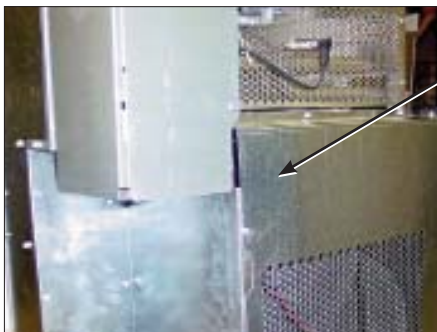

8

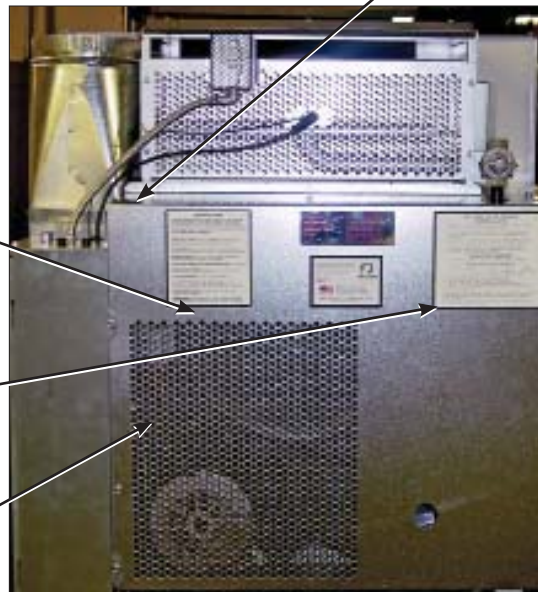

5

11

8

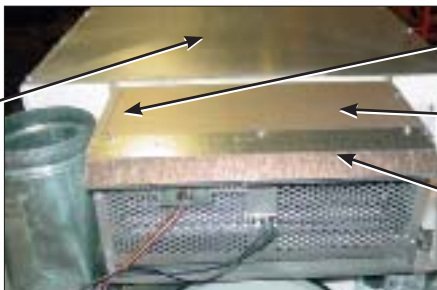

12

15

14

13

# Tumbler Group

Key	Part Number	Description	Quantity
	9848-131-001	Tumbler Assembly Galvanized w/spider.....	2
G2	9568-013-001	Spider Assembly .....	2
G3	9497-226-002	Rod, Tumbler .....	6
G4	8640-417-005	Nut, 1/2 - 13 .....	6
G6	8641-590-002	Washer, Special .....	6
G7	9552-013-000	Shim .....	AR
*	9848-130-002	Tumbler Assembly Stainless Steel.....	2
G1	9848-130-001	Tumber Assembly Galvanized.....	2

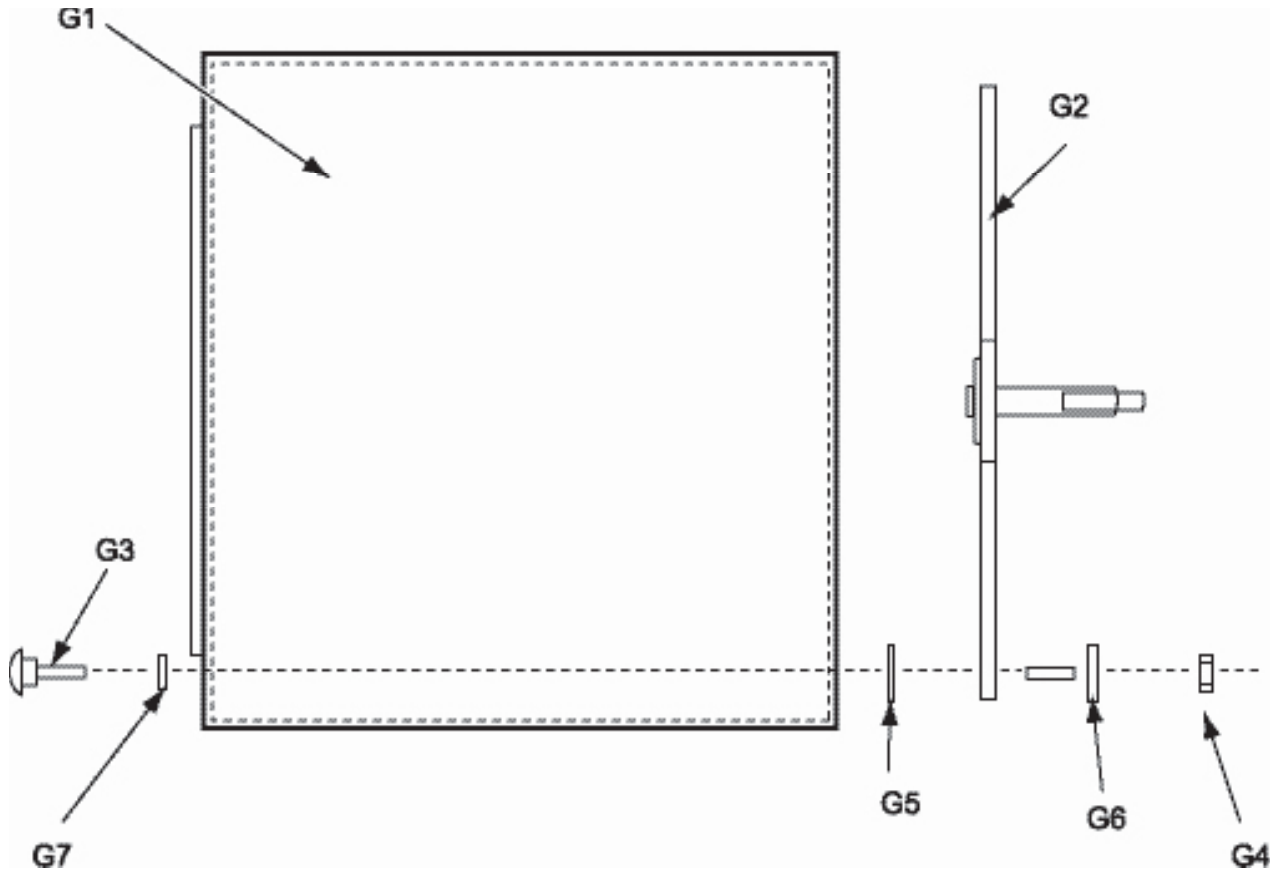

# Control Assembly Group

Key	Part Number	Description	Quantity
*	9857-189-001	Control Assmby Complete (all below included) .....	1
*	9108-117-001	Control Box Cover .....	1
*	8220-001-478	Wire Assembly Green 7" .....	1
*	8639-621-007	Screw #10-32 x 12 Green.....	1
*	8641-582-006	Lockwasher Ext Tooth #10.....	1
3	9897-026-002	Terminal Block Main Power Middle .....	1
4	9897-026-001	Terminal Block.....	2
*	9545-045-012	Screw #8 ABx 1/2 for terminal block.....	6
5	8711-011-001	Transformer Ignition.....	2
*	9545-008-024	Screws 10AB x 3/8" .....	4
6	9982-348-001	Plate Assembly MTG Ignition Control.....	2
*	9545-008-024	Screws 10B x 1/4" MTG Above Plate and Others .....	4
7	9857-116-003	Ignition Control .....	2
*	8640-411-003	#6-32 Nuts .....	4
8	9631-403-009	Wire Assembly High Voltage Upper.....	2
9	9627-860-001	Wire Harness Ignition Control Upper.....	1
10	9627-860-002	Wire Harness Ignition Control Lower.....	1
*	9053-067-002	Bushing Wire 7/8".....	4
13	9200-001-002	Fuseholder Assembly.....	3
14	8636-018-001	Fuse 1.5 Amp.....	3
15	5192-299-001	Relay Power .....	2
16	9897-036-035	Terminal Block Assembly Main Power Inlet .....	1
*	9545-008-024	Screw #8 AB x 1/2" .....	2
*	8220-062-036	Wire Assembly Red/Black 14" .....	1
*	8220-062-037	Wire Assembly Red/White 14" .....	1
*	8220-062-038	Wire Assembly White 14" .....	2
21	9627-864-001	Wire Harness Motor Extension.....	2
*	9527-007-001	Stand Off - Wire Saddle / Arrowhead .....	13
*	9545-031-005	Screw 6 B x 3/8" .....	4
22	9558-029-003	Strip Terminal Marker (Behind Input Power).....	1
*	9627-863-001	Wire Harness Main Extension Access Under Burner Housing .....	1
23	9631-403-008	Wire Ass'y - High Voltage Lower .....	1
25	9627-859-001	Wire Harness - Main Power .....	1

# Control Assembly Group

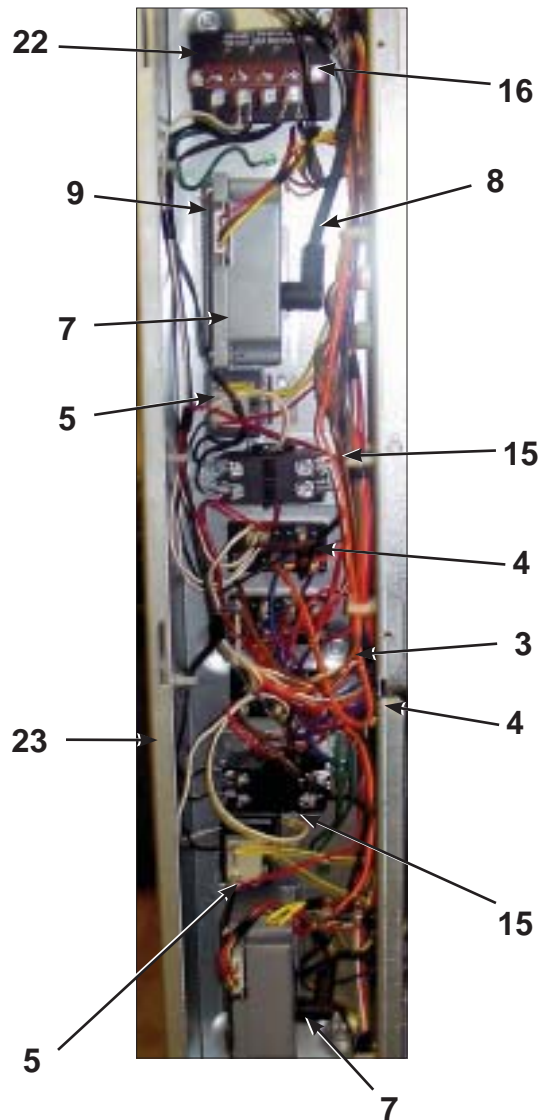
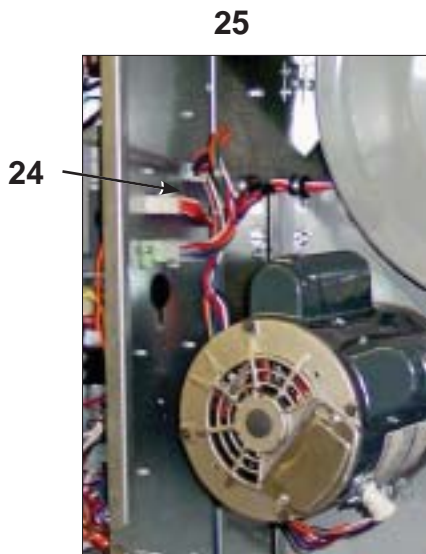
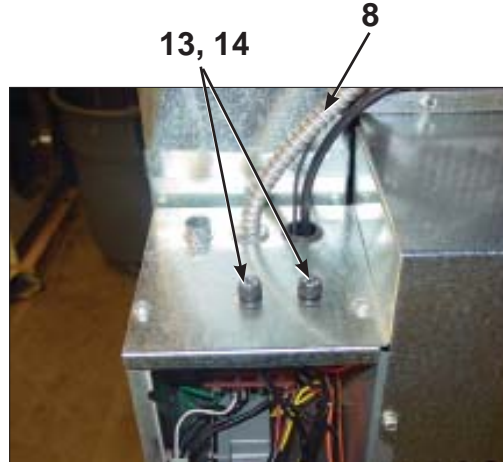
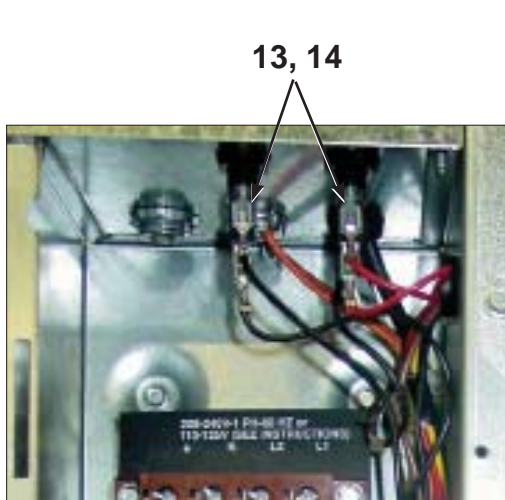

# Coin Handling Group

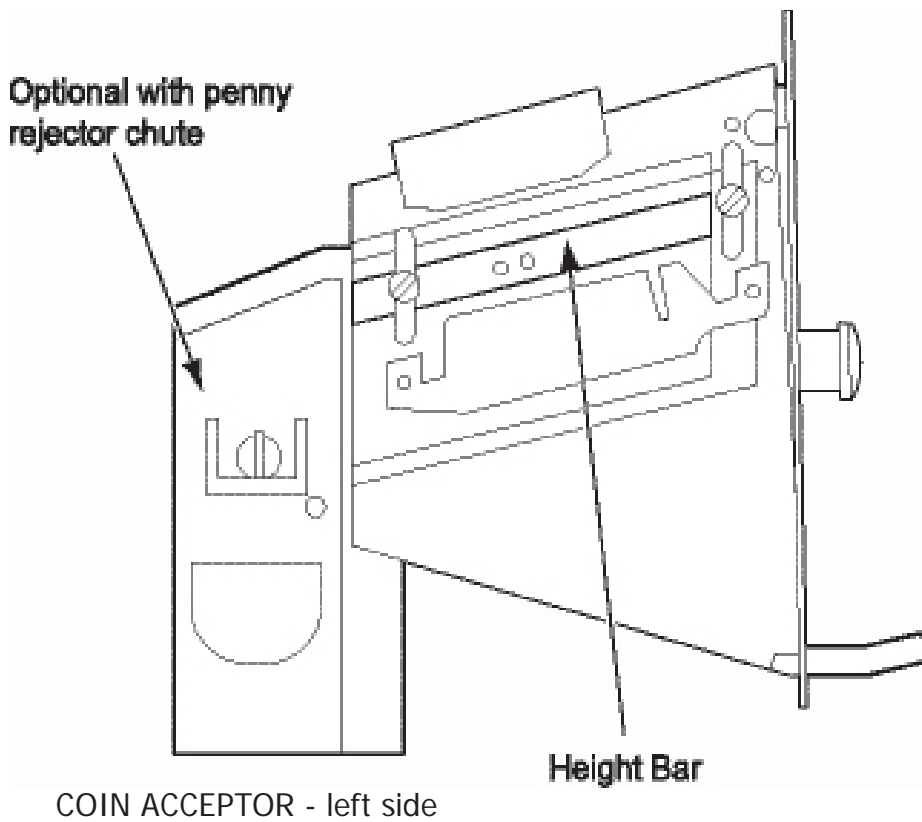
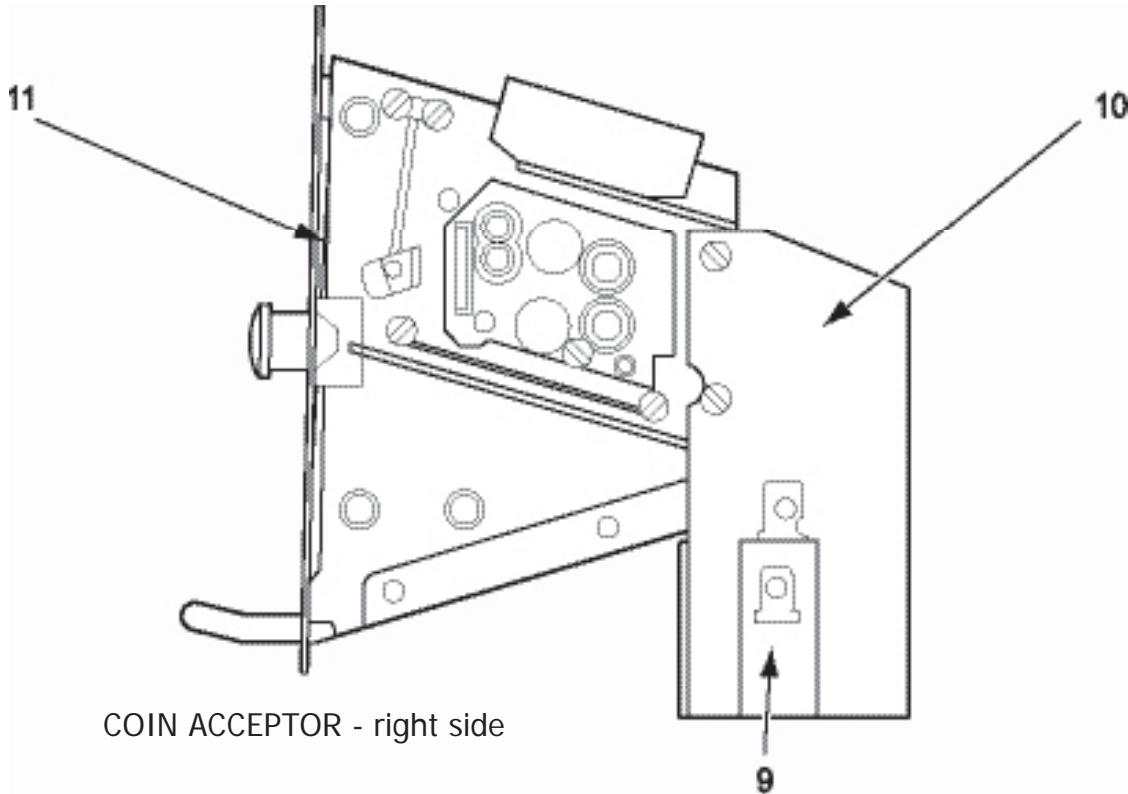



## Coin Handling Group

Key	Part Number	Description	Quantity
*	9942-038-002	Vault, Assembly Gray ( SS front panel ) .....	1
*	9942-038-004	Vault, Assembly Almond .....	1
*	9942-038-003	Vault, Assembly White .....	1
*	9942-038-005	Vault, Assembly Black Large Vault ( SS front panel ).....	1
	Note Large Vault after S/N		
1	9807-099-002	Box Assembly, Coin .....	1
*	9982-338-001	Vault Plate Assembly Coin Vault Mounting.....	1
*	8640-413-004	Nut, Vault Mounting .....	4

NOTE: COIN BOX AND HARDWARE KIT AND COIN BOX LOCK NOT INCLUDED WITH MACHINE.

*	9021-001-010	Acceptor, Coin .....	1
*	9545-053-002	Screw, Acceptor Mtg .....	4
9	9732-126-001	Switch, Coin .....	1
11	9119-025-002	Acceptor Chute Ass'y w/o penny ejector .....	1
*	9119-025-001	OPTIONAL Acceptor Chute W/ penny rejector .....	*



---

## Intergrated EasyCard Ready Machine

Key	Part #	Description	Quantity
	9989-517-009	Panel Assy-Front Lower EC/OPL (SS) .....	1
	9989-517-011	Panel Assy-Front Lower EC/OPL (Wht) .....	1
	9989-517-012	Panel Assy-Front Lower EC/OPL (AL) .....	1
	9506-450-001	Wiring-Schematic .....	1
	9506-451-001	Wiring-Diagram .....	1
	9627-731-001	Harness, Reader .....	1
	9806-013-003	Cable 20' Shielded to unshielded .....	1
	9797-009-001	Card Reader Assy Complete (Includes all Below) .....	1
	9797-006-003	Card Reader .....	1
	8502-729-001	Label-Reader .....	1
	9982-336-001	Plate Assy, Reader mounting (No label) .....	1
	9083-118-001	Clip Retainer .....	1
	9209-088-001	Gromet-Lite pipe .....	2
	9351-099-001	Lense-LED, Lite Pipe .....	2
	9486-156-001	Retainer-Card Reader Assy .....	1
	8640-424-002	Nut-Hex #4-40 .....	3

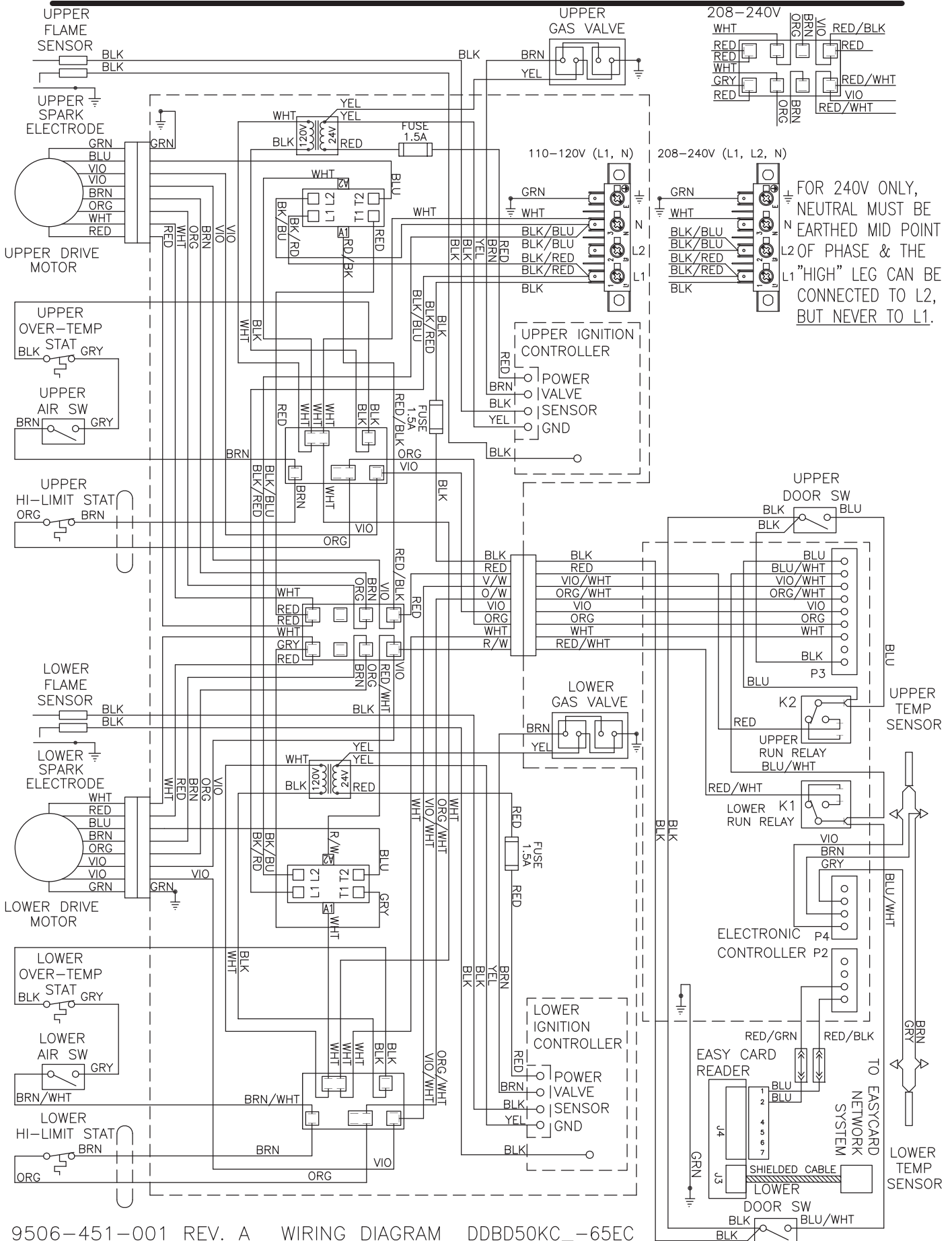

**IMPORTANT: RETAIN THIS ELECTRICAL DIAGRAM FOR SERVICE.**

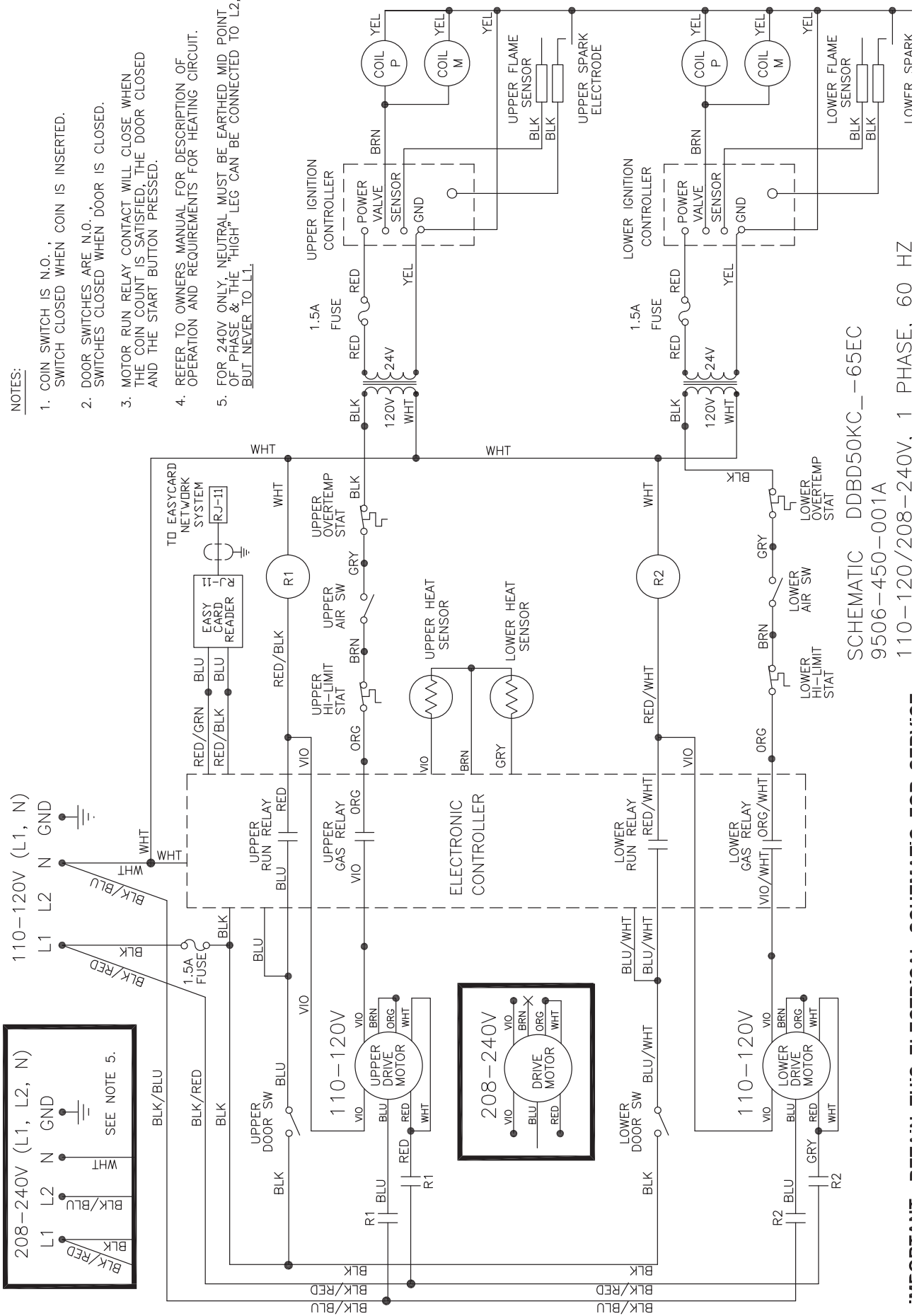

**NOTES:**

1. COIN SWITCH IS N.O., SWITCH CLOSED WHEN COIN IS INSERTED.
2. DOOR SWITCHES ARE N.O., SWITCHES CLOSED WHEN DOOR IS CLOSED.
3. MOTOR RUN RELAY CONTACT WILL CLOSE WHEN THE COIN COUNT IS SATISFIED, THE DOOR CLOSED AND THE START BUTTON PRESSED.
4. REFER TO OWNERS MANUAL FOR DESCRIPTION OF OPERATION AND REQUIREMENTS FOR HEATING CIRCUIT.
5. FOR 240V ONLY, NEUTRAL MUST BE EARTHED MID POINT OF PHASE & THE "HIGH" LEG CAN BE CONNECTED TO L2, BUT NEVER TO L1.

SCHEMATIC DDBD50KC--65EC  
 9506-450-001A  
 110-120/208-240V, 1 PHASE, 60 HZ



---

# Section 7:

## Voltage Conversion

# Instructions - Convert a Dual Voltage Stack Dryer from 120V to 208-240V with Neutral Wire Only

1. Remove incoming power from the dryer. Use a known working voltmeter to check power.
2. Remove the cover of the control box assembly from the dryer using a 5/16" wrench.
3. Move the black/blue wire from the N position of the main power terminal block to the L2 position of the main power terminal block in the control box assembly. See Figure 1 below.
4. Move the white wire of the upper motor harness to an upper inner left terminal in the middle terminal block in the control box assembly. See Figure 1 below.
5. Move the orange wire of the upper motor harness to an upper inner left terminal in the middle terminal block control box assembly. See Figure 1 below.
6. Move the white wire of the lower motor harness to a lower inner left terminal in the middle terminal block in the control box assembly. See Figure 1 below.
7. Move the orange wire of the lower motor harness to a lower inner left terminal in the middle terminal block control box assembly. See Figure 1 below.
8. Reconnect power to the dryer and test to ensure proper operation; one line voltage to L1, one line voltage to L2, the neutral to N, and the earth ground to E.
9. Reinstall the cover of the control box assembly from the dryer using a 5/16" wrench.

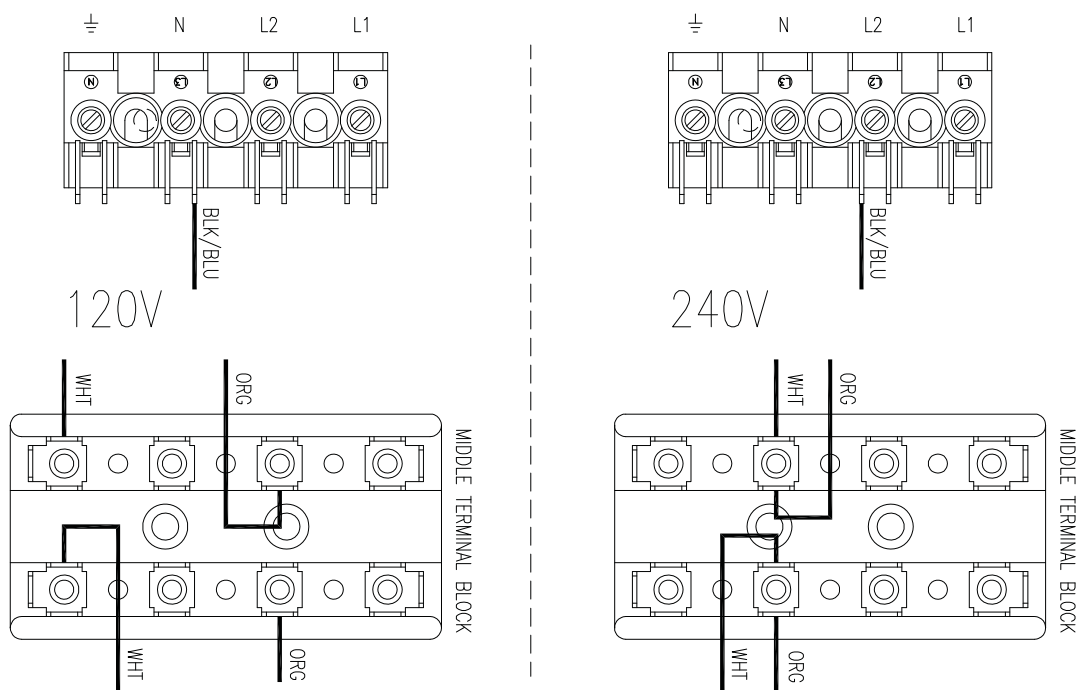

**Figure 1 Dual Voltage Stack Dryer Voltage Conversion**



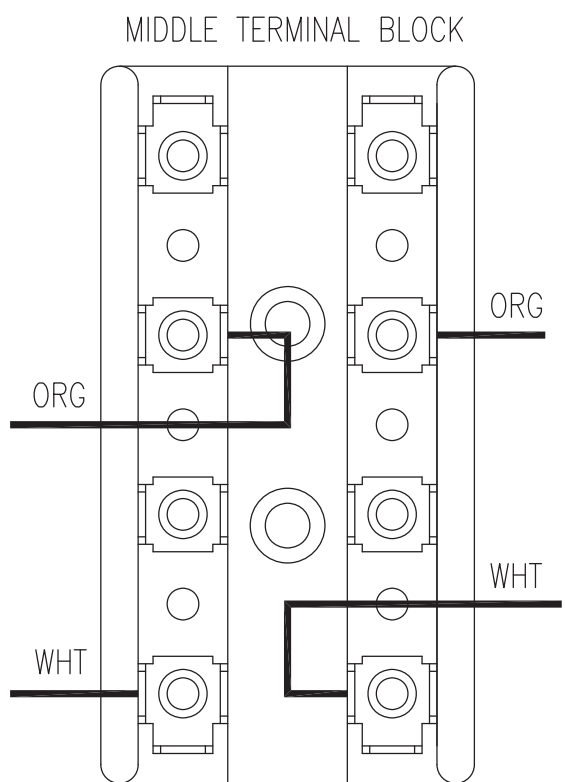
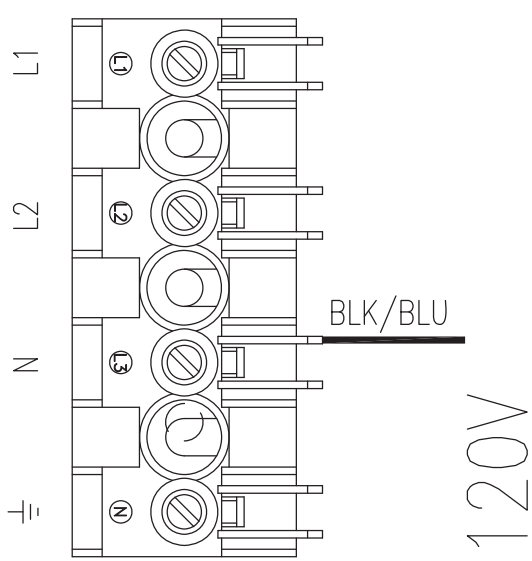
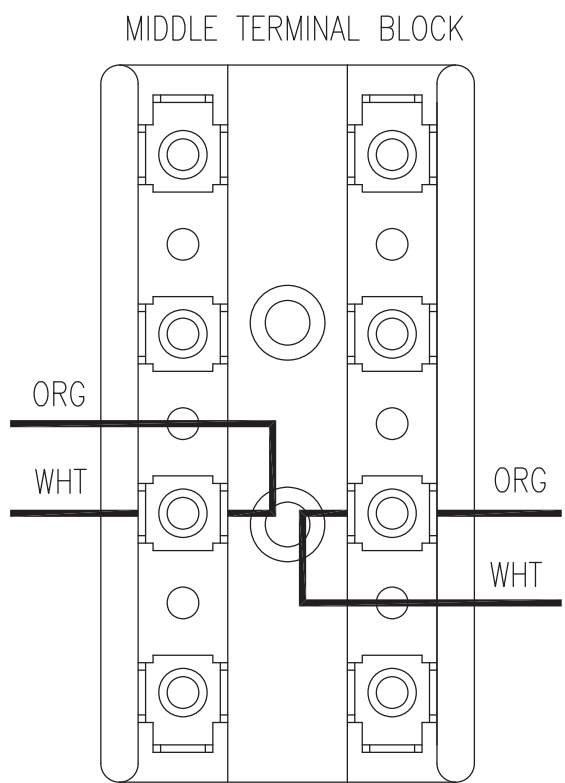
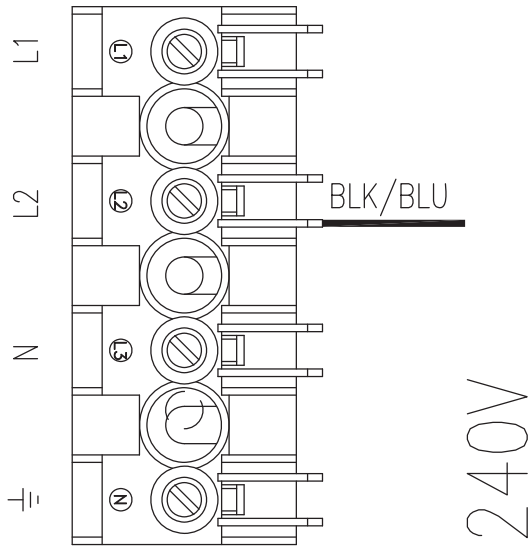

# DUAL VOLTAGE STACK DRYER VOLTAGE CONVERSION



---

# Section 8:

50 hZ

Models

---

# 50HZ Wiring Schematic

## **Dryer Idle - No Coins Added :**

Top Dryer Used For This Example

230 VAC 50 HZ is supplied to the Main Power Terminal Block and passes through a In- line Noise Filter and comes out on BLK/RED and BLK/BLU wire. 230 VAC now passes to a Multitap Control Step Down Transformer and also passes to the Motor Control Relay (R1&R2). When there is power to the dryer the Computer Board will be powered and the display lighted from the 24 VAC secondary side of Control Step Down Transformer. 24 VAC from here is also on one side of the door switch on a black wire. Closing the loading door allows 24 VAC to pass on to the Computer Board on two blue wires. One blue wire makes 24 VAC available to one side of the Motor Run Relay on Computer Board. The other blue wire provides a 24 VAC signal to the Computer Board telling it that the door is closed and door light on the computer board should be illuminated.

## **Coins Added - Motor Starting and Running :**

Top Dryer Used For This Example

As each coin is added the Coin Switch closes and completes a circuit to the Computer Board. The Computer Board counts these signals and registers them against time. The time will display once the Start Button for Upper or Lower is pushed. When the Start Button is pushed again the Computer Board Motor Run Relay closes on the computer. With this Relay closed, 24 VAC is supplied to the Motor Control Relay (R1) on the red wire and also a violet wire going down to motor. The motor LED on the computer board should be illuminated anytime the computer calls for the motor to operate. With (R1) engaged and 230 VAC at motor the Motor Start Switch in motor is drawn in to the start position. In this position the incoming power 230 VAC is supplied directly to the main run winding and through the Start Capacitor to the Auxiliary Winding (start winding). As the Motor comes up to speed, the centrifical switch inside motor opens the circuit to the Start Winding and closes the circuit to allow 24 VAC to pass to the Gas Relay on the Computer Board on the other violet wire. The heat circuit in the dryer can not operate if the motor is not running. The gas LED on the computer board will be illuminated when Computer Board calls for the heat after Motor Centrifical Switch has closed.

---

## Heat Circuit

Top Dryer Used For This Example

With the Drive Motor running and 24 VAC provided to the Computer Board Gas Relay, it will close if Computer Board senses programmed temperature is needed. The violet wire changes to an orange wire out of the Computer Board Gas Relay. When this relay closes it provides 24 VAC to the High Limit Thermostat. The High Limit Thermostat is normally closed. (It will open, turning off the heat circuit, if the dryer can't move enough air from problems such as an exhaust restriction or other problems.) 24 VAC now goes through to the normally open Air Switch (Sail Switch) on the brown wire. This switch is closed only if the dryer is running and has the correct air flow. With the dryer running and the Air Switch closed, 24 VAC is supplied to the normally closed upper manual reset Overtemp Thermostat on the gray wire and changes to the black wire out of switch and then goes to Ignition Step Down Transformer. Now with 24 VAC the red wire on secondary side of the Ignition Step Down Transformer goes to the 1.5 amp in-line fuse that protects the Upper Ignition Controller (GREY BOX). With 24 VAC now supplied to the Upper Ignition Controller (GREY BOX) it will then send high voltage to the Spark Ignition Electrode via the High Voltage Lead Wire (this lead looks like an automotive spark plug wire). The Ignition Control Module (GREY BOX) simultaneously sends 24 VAC to the Gas Valve Coil which opens the Gas Valve and allows gas to pass to the main burner. When ignition occurs the high voltage sparking stops and if Ignition Control Module (GREY BOX) gets a flame sense signal it will allow gas valve coil to remain energized and continue burner operation. If ignition does not occur, the Ignition Control Module (GREY BOX) will spark for 10 seconds before locking out.

## Manual Reset Safety Shutoff Over-Temperature Thermostat

Top Dryer Used For This Example

This thermostat is manually reset by pushing in the red button through the small hole in the cover. The Over Temperature Thermostat is a safety backup for the entire Heat Circuit and located in the recirculation chamber area on the side of the burner housing. If the dryer over heats this Over Temperature Thermostat it opens the line to turn off the heat but leaves the Computer Board lighted and the drive motor powered and turning so the basket will cool down.

## Cool Down

Top Dryer Used For This Example

At the preprogrammed time (2 minutes factory setting - adjustable) the Computer Board will open the Gas Relay Contact. This allows the Drive Motor to continue to run but without heat. The gas light on the computer board should not be illuminated anytime the computer is in cool down. This Cool Down period allows the clothing (zippers, snaps, etc.) time to cool down to a temperature that is easily handled by customers.

## End of Cycle

Top Dryer Used For This Example

At the end of the cool down, the Computer Board opens the Upper Run Relay, which removes power from the Motor Control Relay (R1) and also removes power to the Drive Motor. The motor light on the computer board should no longer be illuminated. The Drive Motor and tumbler stops and the Computer Board display now flashes until the dryer loading door is opened. Once the dryer loading door is opened to remove the clothing the display goes back to vend price.

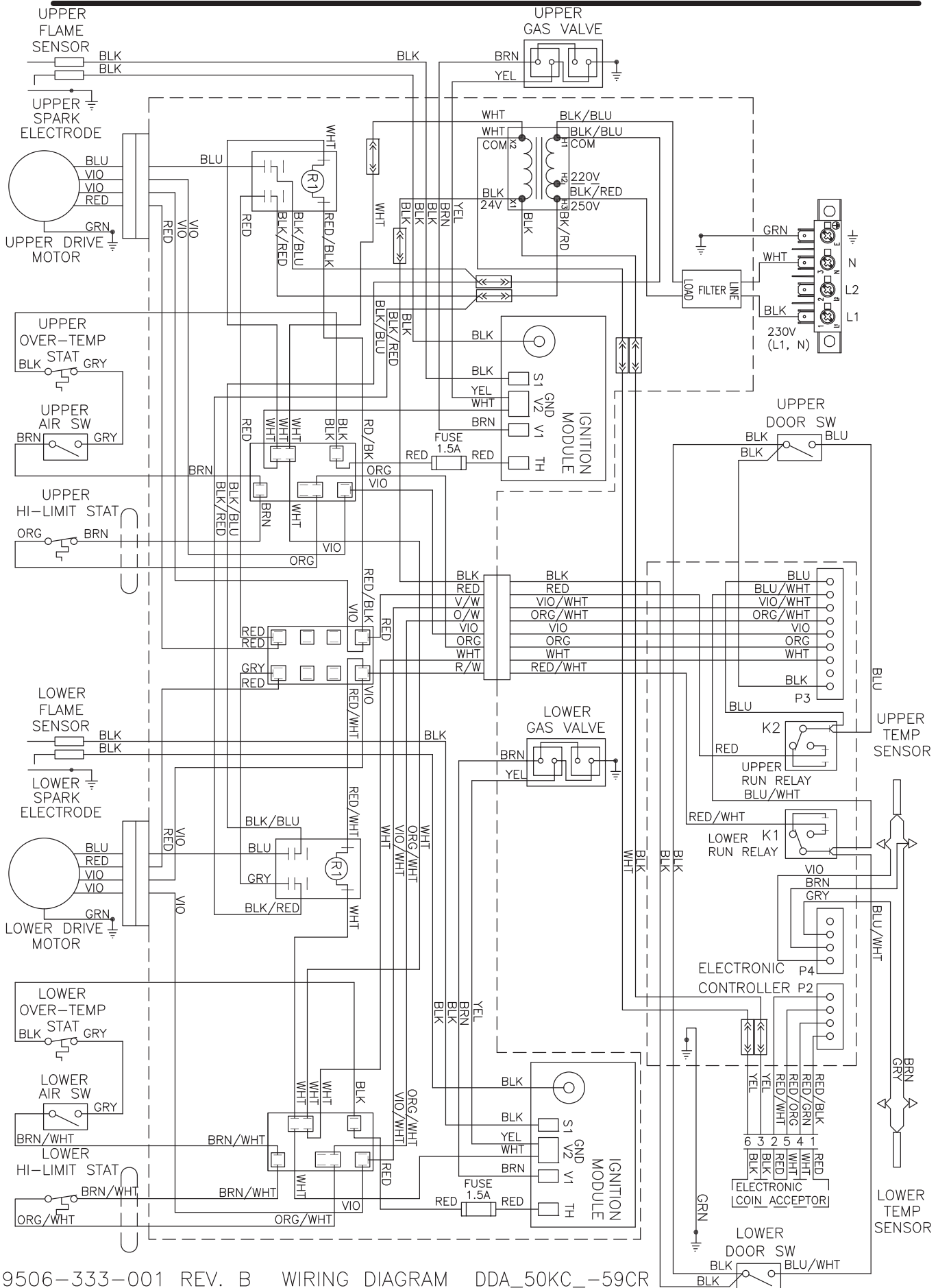

9506-333-001 REV. B WIRING DIAGRAM DDA\_50KC\_-59CR

**IMPORTANT: RETAIN THIS ELECTRICAL DIAGRAM FOR SERVICE.**

**IMPORTANT: RETAIN THIS ELECTRICAL SCHEMATIC FOR SERVICE.**

- NOTES: 1. ELECTRONIC COIN ACCEPTOR-N.O.,CLOSED WHEN COIN INSERTED.  
 2. DOOR SWITCHES-N.O.,CLOSED WHEN DOOR IS CLOSED.  
 3. MOTOR RUN RELAY CONTACT WILL CLOSE WHEN THE COIN COUNT IS SATISFIED,THE DOOR CLOSED AND THE START BUTTON PRESSED.  
 4. REFER TO OWNERS MANUAL FOR DESCRIPTION OF OPERATION AND REQUIREMENTS FOR HEATING CIRCUIT.

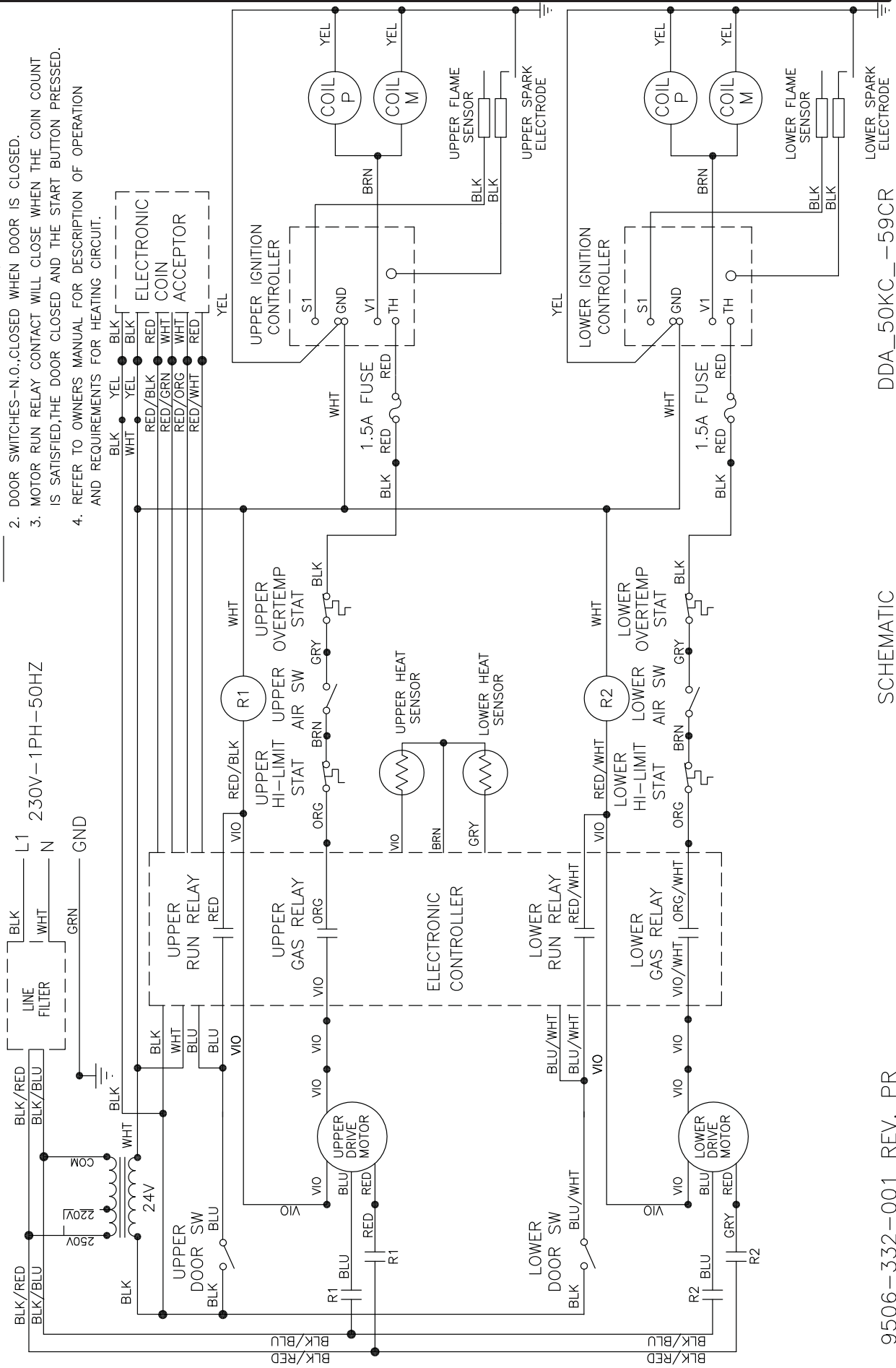

9506-332-001 REV. PR

SCHEMATIC

DDA\_50KC\_-59CR

# DDBD50KC\_-59 Electrical Group

Key	Part Number	Description	Quantity
2	5192-295-017	Relay.....	2
*	8220-065-006	Wire Asy-BLK/RED, 11".....	2
*	8220-065-007	Wire Asy-BLK/BLU, 11".....	2
*	8220-065-032	Wire Asy-BLK, 11".....	2
*	8220-065-033	Wire Asy-WHT, 11".....	2
*	8220-095-043	Wire Asy-BRN, 81".....	2
*	8502-730-001	Label-Warning, Electronic Coin Acceptor.....	1
*	8507-230-003	Instructions-Transformer Connect.....	1
3	8711-008-002	Transformer-Control.....	1
4	9183-030-002	Filter-Line, EMI.....	1
*	9376-314-001	Motor-Dryer, Stack, Marathon.....	2
*	9486-149-001	Retainer-Dual Coin Acceptor.....	2
*	9506-332-001	Wiring Label-Schematic.....	1
*	9506-333-001	Wiring Label-Diagram.....	1
6	9558-029-004	Strip-Marker, Terminal.....	1
*	9627-868-002	Harness-Main input power.....	1
*	9627-871-001	Harness-Motor Extention.....	2
*	9627-878-001	Harness-Ignition Control, Upper.....	1
*	9627-878-002	Harness-Ignition Control, Lower.....	1
5	9857-140-001	Ignition Control.....	2
*	9857-147-002	Control Assembly, Electronic Mounted With Membrane Switch.....	1



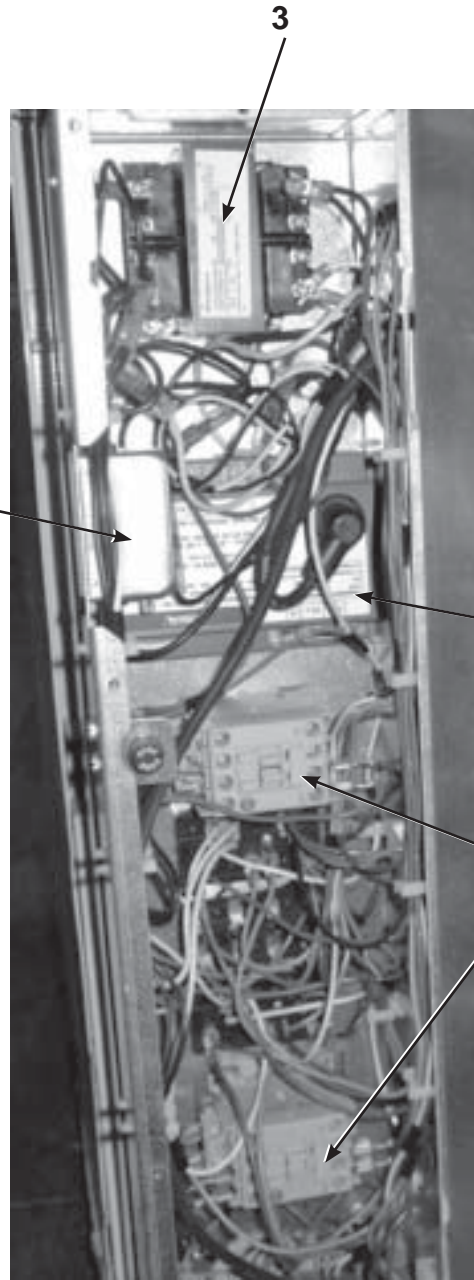
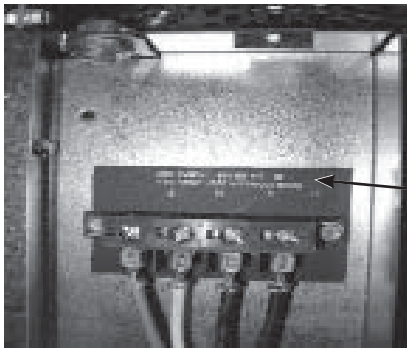

---

## DDBD50KC -59 Gas Control Parts

Key	Part Number	Description	Quantity
1	9732-162-001	Kit-Honeywell VR86 Valve Flange.....	4
*	9791-001-001	Adapter Assembly-Gas Inlit.....	1
2	9857-132-004	Gas Control Valve.....	2

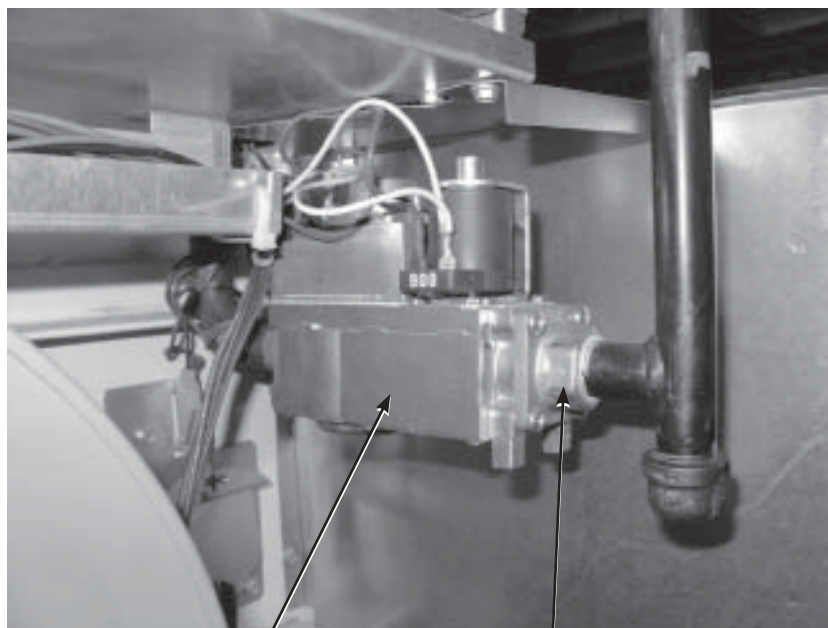

2

1